

MAKING EVERY DROP COUNT



# PIUSI Delphin Pro X Mobile Refuelling Unit

ultraflo  bluequip FUELCUBE *FUELSHOT*



The PIUSI Delphin Pro X is the latest AdBlue car filling equipment, with preset function, automatic flow rate regulation and visual diagnostic alerts.

## Features & Benefits

- Automatic flow rate function adjusts flow rate according to the vehicles tank
- Preset allows the user to pre-define the total amount of AdBlue into the vehicles tank
- Flow Rate: 2-15LPM
- Available in AC and DC
- Includes Delphin Pro X Unit and AF2 Connector
- 2m Hose Length

## Dimensions

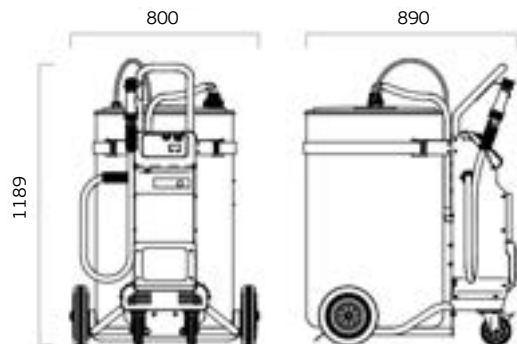

## Part No.

## Description

FP-100040	PIUSI Delphin Pro X 240v AC Mobile Refuelling Unit
FP-100410	PIUSI Delphin Pro X 240v DC Mobile Refuelling Unit